

**TRANSFERRING ENERGY BETWEEN ELECTRIC VEHICLES USING RF
IN A SINGLE-PHASE INDUCTION MOTOR WITH ANN CONTROLLER****¹Dr.CHANDRASHEKHAR REDDY,S, ²SRIKANTH JALA**

¹Professor in EEE, Christu Jyothi Institute of Technology & Science, Jangaon,
Telangana.

²PG Student, Christu Jyothi Institute of Technology & Science, Jangaon, Telangana.

ABSTRACT

Electric vehicles are the ideal option for environmentally friendly and smooth transportation, due to their high efficiency and absence of greenhouse gas emissions. The lack of electric charging facilities is the biggest limitation in the implementation of electric vehicle transportation. This situation can be well modified with smart approaches like vehicle to grid(V2G), vehicle to home(V2H), and vehicle to vehicle (V2V) charging schemes. In V2V, charging is used to synchronize the charging between electric vehicles. Which is needed when electric vehicle users are left without a battery charge and a nearby charging station. Therefore, to overcome the limited number of charging station problems, V2V wireless power transfer (WPT) can be used. With the invention of the wireless charging system, owners of EVs do not need to wait long hours at

a charging station instead they can put their vehicles on charging mode anywhere even at running time. In this proposed system the Wireless V2V power transfer is enabled by measuring and comparing the battery voltage and SoC of EVs. According to the higher or lower value of battery SoC and Voltage level, a singleEV can act as a both transmitter and receiver EV. The designed system is validated through MATLAB/Simulink.

Keywords: *EV, V2v, V2G, inverter, converter, SOC.*

INTRODUCTION

Ever increasing effects of green house gases from the conventional IC engines lead to environmental concerns. This paved to the booming of pollution free electric vehicles (EVs) in the automobile industry [1–3]. However, EV battery charging from the utility grid increases the load demand on the grid and eventually increases the electricity

bills to the EV owners which necessitate the use of alternate energy sources [4, 5]. Due to inexhaustible and pollution free nature of renewable energy sources (RESs), it can be used to charge the EV battery. Thus, RES driven EV can be termed as 'green transportation' [6]. Solar is one of the promising RESs which can be easily tapped to utilise its energy to charge EV battery [7, 8]. Hence, PV array power is used to charge the EV battery in the proposed system with the help of power converter topologies. Lithium ion batteries are widely used in the EV due to its high power density, high efficiency, light weight and compact size [9, 10]. Also, these batteries have the capacity of fast charging and long lifecycle with low self-discharge rate. They also have low risk of explosion if it is over charged or short circuited. During charging, these batteries require precise voltage control. Hence, various power electronic converters with voltage controller are used for charging EV battery. Due to the intermittent nature of the PV array, there is a need for power converters to charge the EV battery. Among different converters, multiport converters (MPCs) are preferred in the onboard chargers of hybrid EVs due to its capability of

interfacing power sources and energy storage elements like PV array, ultracapacitors, super capacitors, fuel cells and batteries with the loads in EV like motor, lights, power windows and doors, radios, amplifiers and mobile phone charger. The MPCs have the drawback of increase in weight, cost and maintenance of the EV as all the sources are placed in the EV itself. Also, the complexity of controller implementation increases in these converter-based EV battery charging system [11–13]. Hence, an off-board charger is proposed in this paper in which the EV battery is located inside the vehicle unit and PV array and backup battery bank are located in the charging station or parking station. Various converter topologies for off-board charging system are presented in the literature [14–16].

Among different converter topology, the sepic converter is preferred due to its capability of working in both boost and buck modes. It also has the advantage of the same input and output voltage polarity, low input current ripple and low EMI [17, 18]. However, during low solar irradiation and non-sunshine hours, there is a need for an additional storage battery bank to charge the EV battery.

This backup battery bank has to be charged in the forward direction and discharged in a reverse direction depending on the solar irradiation. Hence, a bidirectional converter with power flow in either direction is required [19]. The bidirectional converters are classified into non-isolated and isolated converters. Transformer in the isolated converters provides isolation which increases the price, weight and size of the converter. The main concerns of EV are weight and size and hence, non-isolated bidirectional converters are best suited for this application [20–22]. Among various non-isolated bidirectional converter topologies, bidirectional interleaved DC–DC converter (BIDC) is preferred due to its advantages like improved efficiency in discontinuous conduction mode and minimal inductance value, reduced ripple current due to multiphase interleaving technique. Snubber capacitor across the switches reduces the turnoff losses and the inductor current parasitic ringing effect is also reduced by employing zero voltage resonant soft switching technique. These are the added advantages of this bidirectional converter [23–25]. The system in [25] is

an off-board EV battery charging system which charges the EV battery from PV array power through bidirectional DC–DC converter in stand-still condition and EV battery gets discharged to drive the dc load in the EV during the running condition. It has the drawback of charging EV battery only during sunshine hours. To overcome this disadvantage and to charge the EV battery without any interruption, the proposed charger is developed using PV array integrated with sepic converter, bidirectional DC–DC converter and backup battery bank for charging the battery of an EV with fuzzy.

LITERATURE SURVEY

Santhosh, T.K., Govindaraju, C.: ‘Dual input dual output power converter with one-step-ahead control for hybrid electric vehicle applications. The rapid conversion of automotive accessory loads to the electrical domain demands a power converter to interface between the on-board source and storage units with the accessories. This study proposes a simplified structure of dual input dual output (DIDO) with single-stage power conversion for hybrid electric vehicle accessory applications. The topology is synthesised using pulsating source cells.

The generic switch model-based DIDO is realised with power switches based on switch realisation technique. Steady-state and equivalent circuit models describing the converter structure are presented. Numerical simulations were performed with the state-space averaged mathematical model. A one-step-ahead controller is used for inductor current control in conjunction with a mode selection logic to utilise its operating modes based on the availability of the sources and its protection. The performance of the proposed converter and its associated control scheme under steady-state, transient conditions are corroborated by simulation and experimental results.

Shukla, A., Verma, K., Kumar, R.: 'Voltage-dependent modelling of fast charging electric vehicle load considering battery characteristics' : Electric vehicle (EV) integration into the power grids is increasing rapidly. To analyse the effect of charging of EVs on the distribution system, most of the literature considered EV load as constant power load (CPL) which do not represent the exact behaviour of these uncertain loads. An accurate EV load modelling is developed by determining the relationship between power

consumption by EV, grid voltage and state of charges of fast charging EV load. The derived relationship is validated by simulating a realistic fast charging system to obtain a battery charging behaviour characteristics and is curve fitted on standard exponential load model. Further the impact of stochastic 24-h load profile of fast charging EVs considering the exponential load model is investigated on IEEE 123 bus distribution system and is compared with the constant impedance-constant currentconstant power (ZIP) load model and CPL model. The stochastic 24-h load is developed using queuing analysis-based method. The results show that the exponential load model is the better representation of fast charging EV load and 10.19% of the reduction in annual energy demand and 11.19% of the reduction in annual energy loss is observed for exponential load model compared to the existing CPL model.

Wirasingha, S.G., Emadi, A.: 'Pihef: plug-in hybrid electric factor', The potential of plug-in hybrid electric vehicles (PHEVs) to operate in electric and hybrid modes and their ability to supplement the energy storage off the grid have made them a front-runner in alternative fuel vehicle development.

However, there is currently no widely accepted standard classification that provides an accurate comparison of PHEVs. This paper presents a novel classification for PHEVs: “Pihef: Plug-In Hybrid Electric Factor.” Pihef is the average ratio of the energy provided by the grid to the sum of the energy provided by the grid and fuel. The viability of Pihef is demonstrated via comprehensive simulations and a sensitivity analysis. In addition, the relationship between Pihef and emissions, efficiency, hybridization, and electric range is developed.

Kirthiga, S., Jothi Swaroopan, N.M.: ‘Highly reliable inverter topology with a novel soft computing technique to eliminate leakage current in grid-connected transformer less photovoltaic systems’ Grid-connected transformer less photovoltaic inverters are widely accepted in the renewable energy market, owing to their high power density, low cost, and high efficiency. However, the leakage current is the main issue in these inverters, which is to be investigated carefully. In this study, leakage current analysis of both transformer and transformer less bridge inverter topologies are widely investigated. Based on that, a new

topology and modulation technique is proposed to eliminate the leakage current in the system. The mechanism of a creating high-impedance path between the photovoltaic module and the system, by properly isolating them in the freewheeling state and maintaining a constant common mode voltage in all the switching states, is elaborately discussed in this paper. The experimental results are finally presented to validate the proposed topology with respect to other conventional topologies.

Badawy, M.O., Sozer, Y.:

‘Power flow management of a grid tied PV-battery system for electric vehicles charging’ The prospective spread of Electric vehicles (EV) and plug-in hybrid electric vehicles arises the need for fast charging rates. High required charging rates lead to high power demands, which may not be supported by the grid. In this paper, an optimal power flow technique of a PV-battery powered fast EV charging station is presented to minimize the operation cost. The objective is to help the penetration of PV-battery systems into the grid to support the growing need for fast charging of EVs. An optimization problem is formulated

along with the required constraints and the operating cost function is chosen as a combination of electricity grid prices and the battery degradation cost. In the first stage of the proposed optimization procedure, an offline particle swarm optimization (PSO) is performed as a prediction layer. In the second stage, dynamic programming (DP) is performed as an online reactive management layer. Forecasted system data is utilized in both stages to find the optimal solution for the power management. In the reactive management layer, the outputs of the PSO are used to limit the available state trajectories used in the DP and, accordingly, improve the system computation time and efficiency. Online error compensation is implemented into the DP and fed back to the prediction layer for necessary prediction adjustments. Simulation and experimental results are successfully implemented to validate the effectiveness of the proposed management system.

Van Der Meer, D.,
Chandra Mouli, G.R., Morales-Espana
Mouli, G., et al.:

'Energy management system with PV power forecast to optimally charge EVs at the Workplace This paper presents the design of an energy management system (EMS) capable of forecasting photovoltaic (PV) power production and optimizing power flows between PV system, grid, and battery electric vehicles (BEVs) at the workplace. The aim is to minimize charging cost while reducing energy demand from the grid by increasing PV self-consumption and consequently increasing sustainability of the BEV fleet. The developed EMS consists of two components: An autoregressive integrated moving average model to predict PV power production and a mixed-integer linear programming framework that optimally allocates power to minimize charging cost. The results show that the developed EMS is able to reduce charging cost significantly, while increasing PV self-consumption and reducing energy consumption from the grid. Furthermore, during a case study analogous to one repeatedly considered in the literature, i.e., dynamic purchase tariff and dynamic feed-in tariff, the EMS reduces charging cost by 118.44% and 427.45% in case of one and two charging points, respectively, when

compared to an uncontrolled charging policy.

Xavier, L.S., Cupertino, A.F., Pereira, H.A.: 'Ancillary services provided by photovoltaic inverters: single and three phase control strategies : Grid connected photovoltaic (PV) have been inserted in the power systems mainly at low and medium voltage. PV inverters are power electronic based converters with fast response in the range of milliseconds. Besides, due to solar irradiance variation, these converters have excess capacity that can be used to provide ancillary services to the main grid. Traditionally, ancillary services such as reactive power injection and frequency support are provided by hydro and thermal generation. This work is focused on the analysis of how PV inverters can perform ancillary services and support the grid. Control strategies for reactive power injection and harmonic current compensation are explored. Furthermore, the inverter current saturation plays an important role, once high currents can damage the inverter or reduce its lifetime. Case studies for single and three-phase PV inverters are presented. It is observed that the

ancillary service priority must be defined in order to guarantee PV inverter operation under nominal conditions.

WORKING METHODOLOGY

The Battery plays a vital role in the evolution of EVs. Batteries cost, weight, energy density, charging time, and lifetime are still difficulties for the commercialization of EVs. However, the charging time of the battery has a deep dependence on the attributes of the battery chargers [5]. Wireless charging is an emerging technology that can be applied to a wide range of portable consumer electronic devices. It has become popular due to the elimination of direct electrical contacts to make the system safe and userfriendly. Numerous wireless power transmission applications, such as two and three- dimensional battery charging systems, can make advantage of this novel technology [7]. A charging pad provides electricity to smartphones, laptops, etc. in the event of two-dimensional systems without a direct cable connection. Similar to wired chargers, this offers effective wireless charging of several devices. In addition, it allows for full spatial freedom for charging devices in any location and

orientation on the charging pad, providing the ultimate solution for the convenient charging of personal electronic devices.[8]. The main component in WPT is the transmitter and receiver coil. There are different coil types in WPT systems, such as square, circular, rectangular, and bipolar. [7].

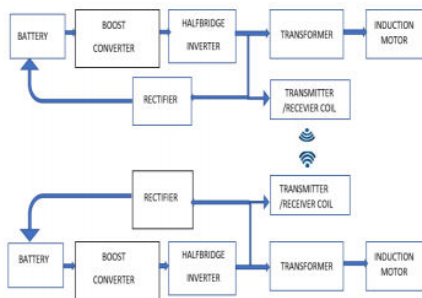

Fig 1. shows the block diagram of V2V power transfer using transmitter and receiver coils (wireless Transmission). The energy from one battery transfers to another vehicle battery according to the setting in the vehicle. If EV1 has higher energy than EV2, then energy from EV1 battery is transmitted to EV2 battery and if EV2 has higher energy than EV1, then energy from EV2 battery is transmitted to EV1 battery using proper control schemes. Here in this system, a single EV consists of a single coil that can act as both transmitter and receiver coils. When the coil act as a receiver, the energy received through the coil gets rectified through the rectifier circuit and given to the battery for recharge the

battery. When the coil act as a transmitter coil, the energy from the battery is discharged wirelessly. The block diagram shows the wireless transmission of EVs while running the vehicle. The boosted DC voltage from the battery is converted to AC voltage. This low AC voltage is stepped up and given to the induction motor, at the same time by evaluating the SOC (State of Charge) of both battery, transmitter, or receiver circuit gets activated. If the SOC of the EV1 battery is higher than the EV2 battery then the transmitter circuit of EV1 and receiver circuit of EV2 get activated. In this way, the power is transmitted between the EVs using a single coil. i.e., Both transmitter and receiver circuit is connected to a single coil using a DPDT switch, which enables the system to choose the transmitting/ receiving circuit operation according to the system need using a single coil.

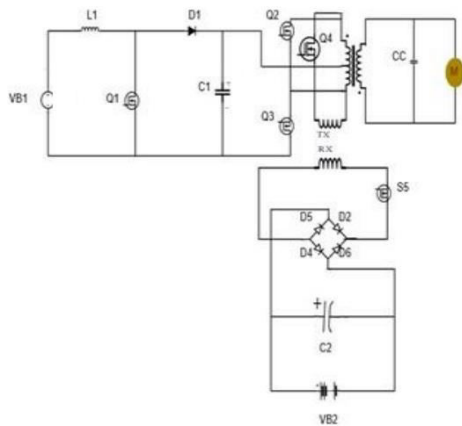

Fig.2. Circuit diagram.

Fig shows circuit diagram of the battery discharging circuit of EV1 and the battery charging circuit of EV2. Battery discharges through boost converter – Half bridge Inverter to induction motor and charges through the bridge rectifier. i.e., The primary side of a high-frequency inverter converts DC electricity to high-frequency AC. On the secondary side, high-frequency AC energy is converted to DC power, rectified, and then filtered to provide a current that is ripplefree and capable of charging EV batteries. The resonant frequency of the compensatory topologies and coils defines the needed switching frequency of the inverters. If EV1 has higher energy than EV2, then switch Q4 and S5 turned on which activates the transmitter circuit of EV1 and the receiver circuit of EV2. Initially,

the battery voltage gets boosted using the boost converter.

SIMULATION STUDIES AND RESULTS

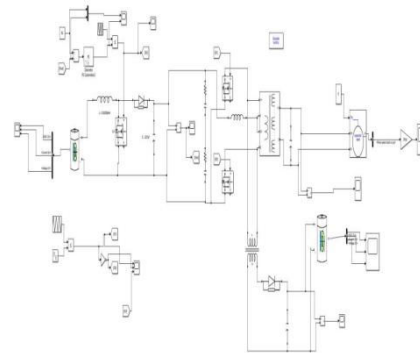

Fig.3. Simulation circuit.

When Q1 is turned on L1 gets charged and stores the energy from the battery VB1 and when Q1 is turned off the stored energy and the battery voltage are given as the input of the inverter. The inverter then converts the boosted voltage into AC voltage by alternately turning on and off switches Q2 and Q3. The inverted low voltage AC is stepped up using a transformer and given to the induction motor. This forms the induction motor drive circuit. So if a vehicle (EV1) in the roadway needed more energy to reach a much further destination, then the other vehicle (EV2) traveling a shorter distance could wirelessly charge the long-distance vehicle at low power

while in motion by turning on the switches Q4 and S5 of EV1 and EV2.

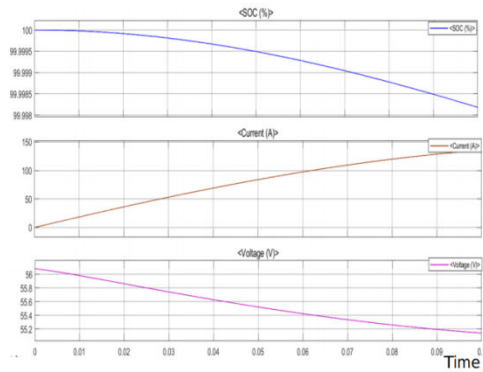

Fig.4. EV1 discharging.

The receiver coil picks up a current when the alternating current energizes the transmitter coil, creating a magnetic field. An oscillating magnetic field is used to transmit energy inductively from a transmitter to a receiver during the power transfer. To achieve this, specially created electronics built within the transmitter convert Direct Current (DC), supplied by a power source, into high-frequency Alternating Current (AC). A copper wire coil in the transmitter is energized by the alternating current, creating a magnetic field. When a second coil (the receiver coil) is put close to the magnetic field, the magnetic field can cause the receiving coil to produce an alternating current. After being transformed back into direct current, the supplied alternating current now provides useful power.

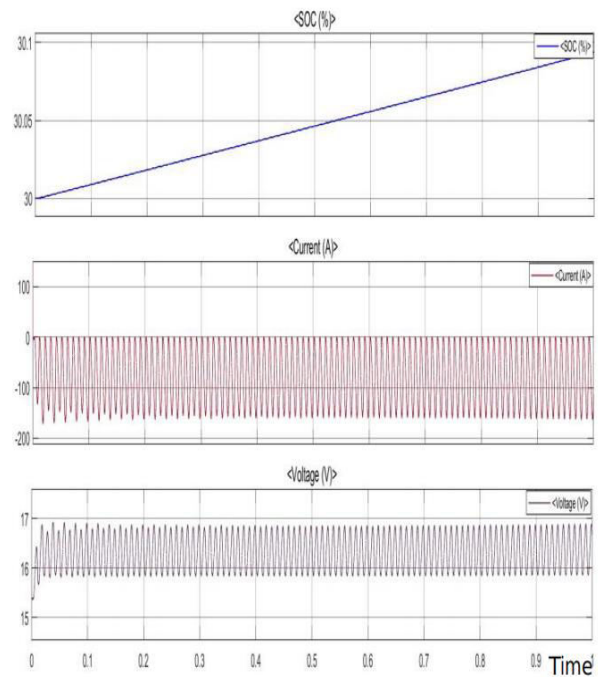

Fig.5. Charging of EV2

The output waveform is obtained after the simulation is given. The charging and discharging of EV1 and EV2 are analyzed using the battery soc, voltage, and current measurement. The boost converter switch is controlled by controlling the duty. Inverter switches are controlled using PWM pulses. Since the simulation is done for wireless power transfer while the motor is in running condition, the speed of the induction motor is also observed.

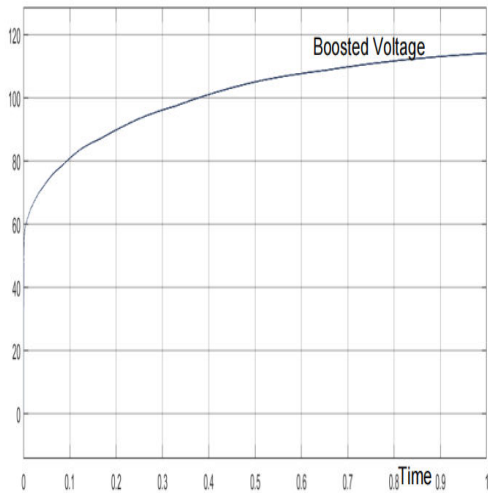

Fig.6. Boost converter output

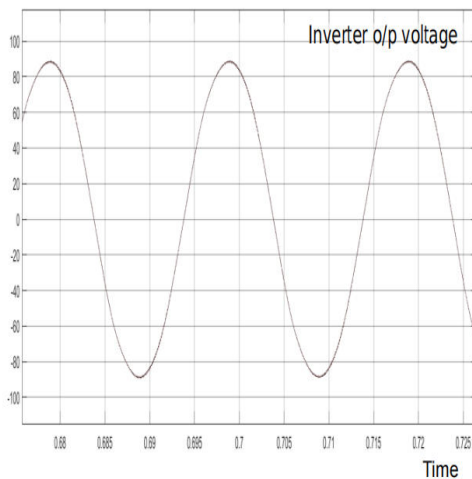

Fig.7. Output of inverter

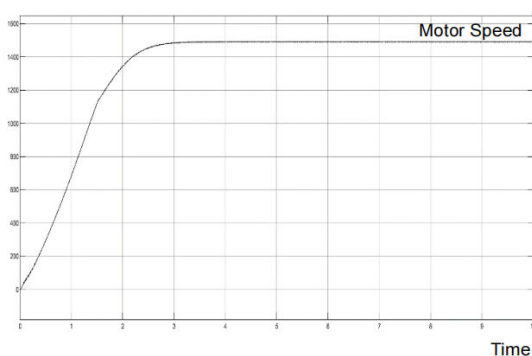

Fig.8. Speed of induction motor.

CONCLUSION

In this project, the proposed wireless power transfer between EVs corresponds to their SOC measurements. MATLAB simulations of wireless power transfer have been done with batteries having different SOC levels. With the invention of the wireless charging system, owners of EVs do not need to wait long hours at a charging station instead they can put their vehicles on charge anywhere even at running time. V2V wireless power transfer (V2V WPT) is an innovative solution that can address the challenges impeding the wide adoption of EVs. Although the non-contact transfer of power (WPT) in the V2V can lead to energy loss (compared to contact transfer), eliminating the need for detours to reach charging stations can create energy savings.

REFERENCES

[1] Santhosh, T.K., Govindaraju, C.: ‘Dual input dual output power converter with one-step-ahead control for hybrid electric vehicle applications’, IET Electr. Syst. Transp., 2017, 7, (3), pp. 190–200

[2] Shukla, A., Verma, K., Kumar, R.: ‘Voltage-dependent modelling of fast charging electric vehicle load considering battery

characteristics’, *IET Electr. Syst. Transp.*, 2018, 8, (4), pp. 221–230

[3] Wirasingha, S.G., Emadi, A.: ‘Pihef: plug-in hybrid electric factor’, *IEEE Trans. Veh. Technol.*, 2011, 60, pp. 1279–1284

[4] Kirthiga, S., Jothi Swaroopan, N.M.: ‘Highly reliable inverter topology with a novel soft computing technique to eliminate leakage current in grid-connected transformerless photovoltaic systems’, *Comput. Electr. Eng.*, 2018, 68, pp. 192–203

[5] Badawy, M.O., Sozer, Y.: ‘Power flow management of a grid tied PV-battery system for electric vehicles charging’, *IEEE Trans. Ind. Appl.*, 2017, 53, pp. 1347–1357

[6] Van Der Meer, D., Chandra Mouli, G.R., Morales-Espana Mouli, G., et al.: ‘Energy management system with PV power forecast to optimally charge EVs at the workplace’, *IEEE Trans. Ind. Inf.*, 2018, 14, pp. 311–320

[7] Xavier, L.S., Cupertino, A.F., Pereira, H.A.: ‘Ancillary services provided by photovoltaic inverters: single and three phase control strategies’, *Comput. Electr. Eng.*, 2018, 70, pp. 102–121

[8] Krithiga, S., Ammasai Gounden, N.: ‘Investigations of an improved PV system topology using multilevel boost converter and line commutated inverter with solutions to grid issues’, *Simul. Model. Pract. Theory*, 2014, 42, pp. 147–159

[9] Sujitha, N., Krithiga, S.: ‘RES based EV battery charging system: a review’, *Renew. Sustain. Energy Rev.*, 2017, 75, pp. 978–988

[10] Farzin, H., Fotuhi-Firuzabad, M., Moeini-Aghtaie, M.: ‘A practical scheme to involve degradation cost of lithium-ion batteries in vehicle-to-grid applications’, *IEEE Trans. Sustain. Energy*, 2016, 7, pp. 1730–1738

[11] Zubair, R., Ibrahim, A., Subhas, M.: ‘Multiinput DC–DC converters in renewable energy applications – an overview’, *Renew. Sustain. Energy Rev.*, 2015, 41, pp. 521–539

[12] Duong, T., Sajib, C., Yuanfeng, L., et al.: ‘Optimized multiport dc/dc converter for vehicle drive trains: topology and design optimization’, *Appl. Sci.*, 2018, 1351, pp. 1–17

[13] Santhosh, T.K., Natarajan, K., Govindaraju, C.: ‘Synthesis and implementation of a multi-port dc/dc

converter for hybrid electric vehicles', J. Power Electron., 2015, 15, (5), pp. 1178–1189

[14] Hongfei, W., Peng, X., Haibing, H., et al.: 'Multiport converters based on integration of full-bridge and bidirectional dc–dc topologies for renewable generation systems', IEEE

Trans. Ind. Electron., 2014, 61, pp. 856–869

[15] Shi, C., Khaligh, A.: 'A two-stage three-phase integrated charger for electric vehicles with dual cascaded control strategy', IEEE J. Emerging Sel. Topics Power Electron., 2018, 6, (2), pp. 898–909