

SOLAR AND BATTERY POWERED E CYCLE

N. BHANU PRAKASH, P. UMA SANTHOSHI

Mr. M RAMBABU, Associate Professor, ECE Department

**SAI SPURTHI INSTITUTE OF TECHNOLOGY, B. Gangaram, Sathupalli mandal,
Khammam District, Telangana.**

Abstract: Global warming and increasing fuel prices in India, taking these two problems in consideration, it is the step towards reducing the use of more fuel consuming vehicles and attract the eye of people towards its alternatives i.e. Solar bicycle. The main aim of this project is to present the idea of harnessing the various energy and use it in today's existence of human life. Now-a-days there are so many vehicles on road, which consumes more fuel and also hazards our environment. A method of upgrades a conventional electric powered bicycle over to Solar-Powered Electrical Bicycle that is powered by an electric motor which gets its supply from photovoltaic (PV) panels.

Keywords: Dynamo, Motor, Hub-motor, Travelling, Electric Bike, Electric Energy, Solar Panels, Fuel Economy etc.

I. INTRODUCTION

Electrical vehicles are claiming a place in several industries, especially in the fields of transportation. The application of electric motors in bicycles and cars opens up a new possibilities and larger number of advantages. Electric motor vehicles are a concept to take into account in the present and even more in the future, as they can open new possibilities and even replace the possibilities given nowadays by the common IC engines. In the current days, fully electrical cars can already directly compete with an internal combustion car or even overcome and make them look absolute in several aspects.

We have to introduce our new project about "Solar Powered Electric Bicycle" which runs with the help of sun light without any fuel. In this project we have implemented our ideas to future generations for transportation. In our solar bicycle solar energy is converted into electrical energy by means of solar panel, battery, solar controller. The electrical energy is stored in the battery and supplied to hub motor through controller. This project deals with this system, which convert solar energy to electrical energy. The main objective of our project is now a days the usage of bicycle for shorter distance has reduced because of the pedaling, time etc. Our project about solar powered electric bicycle which runs with help of both sunlight and the help of pedaling. The solar energy is converted into electrical energy by solar panel, battery, converter and the power is transmitted to the hub motor to run the cycle. We hope that this model bicycle runs with the operation of no emission. Due to this in upcoming years the usage of the bicycle for shorter distance will be increased and it also helps to reduce the pollutions like air & noise.

In our solar bicycle solar energy is converted into electrical energy by means of solar panel, battery, solar controller. The electrical energy is stored in the battery and supplied to hub motor through controller. This project deals with this system, which convert solar energy to electrical energy. The main objective of our project is Now a days the usage of bicycle for shorter distance has reduced because of the pedaling, time etc.

Our project about solar powered electric bicycle which runs with help of both sunlight and the help of pedaling. The solar energy is converted into electrical energy by solar panel, battery, converter and the power is transmitted to the hub motor to run the cycle. We hope that this model bicycle runs with the operation of no emission. Due to this in upcoming years the usage of the bicycle for shorter distance will be increased and it also helps to reduce the pollutions like air & noise.

II. PROBLEM STATEMENT

There are several problems that occur during upgrades a conventional electric powered bicycle to Solar-Powered Electrical Bicycle. The specifications of photovoltaic (PV) panels must be sufficient to generate the electric motor same as a conventional electric powered bicycle. The suitable connection of solar cells, rechargeable battery and DC electric motor with bicycle needed to make sure this project accomplish with more optimum energy use. The electric motor must to support the weight and size of the bicycle, size of solar panel and condition of the road surface.

III. SCOPE OF WORK

The scope of this project is to develop a Pedal-Solar Powered Electrical Bicycle that is powered by an electric motor which gets its supply from photovoltaic (PV) panels and partially uses solar energy. This project will focus on how to apply the photovoltaic (PV) panels on the electric bicycle in term of:

1. Speed of a Solar-Powered Electrical Bicycle compared to electric powered bicycle.
2. Performance of DC motor Solar-Powered Electrical Bicycle compared to electric powered bicycle.

3.1 Project Objectives

The main objective of our project is designing an electric bicycle that operates on Pedal mechanism and solar energy gained from the solar panels attached without the need of human effort or using fuel to run it. Our project will be relying on a system that can track the sun and control the movement of the bicycle. Another aspect of our project is to be able to manage power consumption using solar renewable energy and to store the power gained in a chargeable battery used to move the bicycle and to maximize the utilization of the sun through tracking the sunlight during the day.

IV. LITERATURE REVIEW

In 2012 Lomonova, E. A. The paper discusses the generic mechanical, electromechanical, electromagnetic, control design and test approaches leading to the system integration, design solutions and physical implementation of electrically assisted bicycle as a result of the co-operative research work done by the Dutch Company - ID Bike and Technical University of Eindhoven.

In 2016 Dumitrache, Florin, Marius Catalin Carp, and Gheorghe Pana said that, The electric vehicles industry is continuously evolving. A such electric vehicle is the electric bicycle (e-bike). Electric bicycles, like another electric vehicles, implement a BLDC motor (Brushless Direct Current Motor). This paper presents a way of designing and using an electronic module for an e-Bike. The paper shows how a low power, 8-bit micro-controller can be used to drive such a motor and also manage other useful functions on an e-Bike.

Gebhard et al. (2016) presented a study on e-bikes, in which the battery parameters and the GPS coordinates were measured for the investigation of users' travel patterns. The results of his study show the range of the trip, the distance traveled per participant, the state of charge (SoC) of the battery, and its relation with the users' charging habits.

Behrendt (2017) investigated e-velomobility, based on a field trial with e-bikes conducted in the UK [47]. Kroesen (2017) addressed the question of whether e-bikes can substitute travel by other transportation modes, and to what extent, using data from OViN (Onderzoek Verplaatsingen in Nederland), in The Netherlands. He concluded that e-bike ownership can mainly replace the conventional bikes in The Netherlands, followed by the car or other transportation modes.

V. BLOCK DIAGRAM

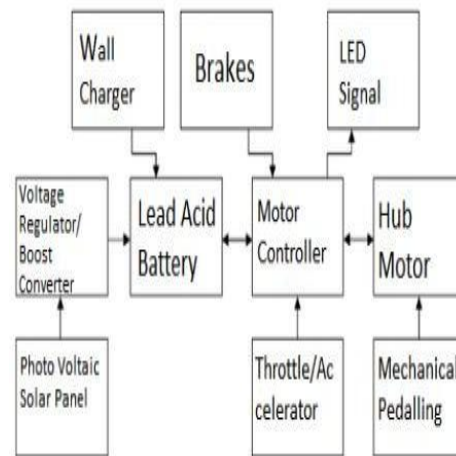

Fig. 1. Block Diagram of system

5.1 Working

The block diagram hybrid bicycle driven by DC motor fitted on middle shaft of bicycle & operated by battery energy shown in fig1. The solar panel mounted on carriage. Solar panel generates 12v power when sun light falls on it and its terminals are connected to charge controller.

Dynamo (motor) is mounted on side shaft of bicycle, supports in such a manner that dynamo shaft is touching the back wheel tyres. As wheel rotates dynamo shaft rotates and generates 12V power. Its terminals are also connected to charge controller. When the bicycle is idle in day time, the solar panel will charge the battery. Due to non-uniform sunlight and varying in wheel speed, output voltage from both solar panel and dynamo is varying in nature. Charge controller adjusts the constant voltage of 12 volt and charges the battery. The power flow acts in parallel with the power delivered by the rider via the pedaling. The rider of an solar bicycle can opt the motor completely

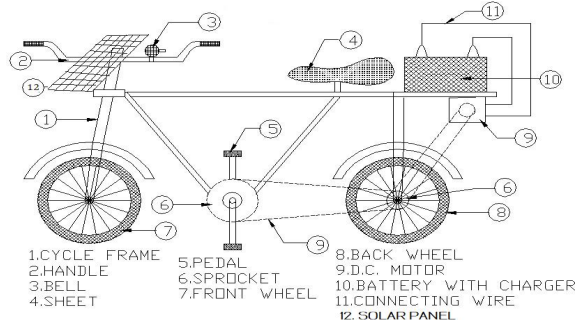

Fig.2. Schematic Diagram of Project

5.2 Components Specification

A. Hub Motor

The hub motor is a conventional Dc motor. The rotor is outside the stator with the permanent magnets mounted on inside. The stator is mounted and fixed onto the axle and the hub will be made to rotate by alternating currents supplied through batteries



**Fig. 3. Hub Motor Rotor
Hub Motor Stator**

B. Solar cells/Panels

Solar cells are electrically connected and fabricated as a module with a sheet of glass on top to allow light to pass and protect the semiconductor from the weather. To obtain a desired peak DC voltage we will add solar cells in series, and to obtain a desired peak current, the solar cells are put in parallel position



Fig 4 Solar Panel

C. Voltage Regulator

A voltage regulator/boost converter is a power converter that will take in a DC voltage and output a higher value DC voltage. Our voltage regulator/boost converter requires output of the solar panel, which can range from 0V to 27.2V, and output for charging of the battery.



Fig 5 Voltage Regulator

D. Lead Acid Battery

Lead acid batteries are one of the most popular types of battery in electronics. Although slightly lower in energy density than lithium metal, lead acid is safe, provided certain precautions are met when charging and discharging. This have a many advantages over other conventional types of batteries, the lead acid battery is the optimum choice for a solar assisted bicycle.



Fig 6 Lead Acid Battery

E. Accelerator/Throttle

Throttle allows us to drive the motor from zero speed to full speed. The throttle is fitted on right side of the handle bar and is connected to controller. The throttle converts DC voltage from battery to an alternating voltage with variable amplitude and frequency that drives the hub motor at different speeds.



Fig 7 Throttle

F. Frame

The frame is the main component of a bicycle, it's the component that connects all the other bicycle parts and where these are fitted in. It has extreme influence in the bicycle performance, safety and nearly all aspects of the bicycle.



Fig 8 Cycle

G. E – Brake Lever

The e – brake lever is a replacement for the regular brake lever and either cuts out the controller or engages regenerative braking in the controller when the lever is squeezed.



Fig 9 Brakes

H. Braking System

For the braking system it is convenient to use braking system used in band brake system which consist of spring loaded friction- shoe mechanism, which is driven with the help of hand lever.

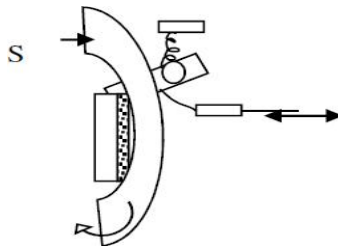

Fig 10 Braking system

I. Chain Drive

A Chain is an array of links held together with each other with the help of steel pins. This type of arrangement makes a chain more enduring, long lasting and better way of transmitting rotary motion from one gear to another.



Fig 11 Chain Drive

J. Sprockets

The chain with engaging with the sprocket converts rotational power in to rotary power and vice versa. The sprocket which looks like a gear may differ in three aspects.

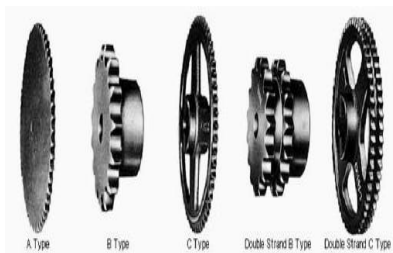

Fig 11 Chain Sprockets

5.3 Advantages

- It is one of the most used, cleanest and sustainable forms of energy obtained through solar cells.
- It is environmental friendly with no use of any fuels or release of toxic fumes that may cause global warming.
- Solar cells are independent form a power source and can charge constantly which helps lower time to charge through a high AC voltage charger.
- It also has a long life span of at least 20 years and requires little maintenance.
- Lesser maintenance cost.
- Normal pedaling is possible when not on power assist mode.
- Detachable battery can be taken inside the house for charging.
- Thumb throttle - simple to operate and less strain on hands.
- Solar panels keep charging the batteries for our continuous use.
- The unit cost is very low.

5.4 Disadvantages

- Price of Motor, battery and solar panel increases with the increase in energy demand of consumer.
- Sunlight is not always available, especially at night and may not be evenly distributed where you are located.
- Both Solar cell and dynamo cannot always provide the sufficient amount of power so they cannot be used as primary source of charging.

5.5 Applications

- Hybrid powered bicycle can be used as transportation vehicle in cities instead of petrol vehicles; because of small in size it can avoid traffic jam.
- Young, aged, physically challenged people can use it for short distance travelling.
- Any bicycle can be modified as a hybrid powered electric bicycle.
- For children small hybrid powered bicycle can be used as a kids cycle.

VI. RESULTS

Expected results using pedal arrangement Using pedal arrangement for charging battery:

Voltage rating for motor = 12-24 V

Rated speed = 1800 – 3900 rpm Current rating = 14 Amps Power rating = 16 – 33 HP

Lead acid battery = 12 V battery

Bike wheel to pulley turn ratio is 26'' diameter to 2'' diameter = 1:13 15 – 16 miles hours of speed are required to charge a battery of 15 volts.

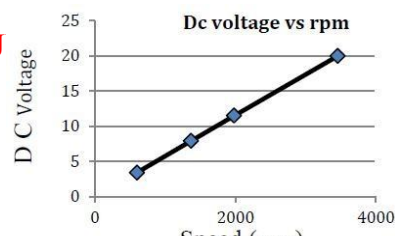

Graph of DC Voltage v/s Speed in RPM *The Relationship of BCC Voltage with Local Time*
Figure shows the comparison of the voltage generated by a flexible solar panel using a PWM and MPPT. The experiment of this battery charging controller (BCC) is two hours.

1. Prevent the motor from overloading as initial torque requirement is full filled by using pedals.
2. As we are giving initial torque by pedals, no need of high-power motor which are use in traditional solar bicycles for same speed requirements.
3. There are no chances of short circuit.
4. As it does not require high power motor, subsequently the requirement of high-power battery and solar panels falls which results in reduction of overall cost of bicycle.
5. Everyone in India can buy this cycle as it is cheap, robust, ecofriendly and We affordable to all.

VII. CONCLUSION

The project carried out by an impressing task in the field of automobile department. It is very useful for having the two wheelers, because need not to spend the lot of money for the fuel. This project will reduce the cost involved in the concern. Project has been designed to perform the entire requirement task at the shortest time available. Due to this pollution can be controlled. Solar assisted bicycle is modification of existing bicycle and driven by solar energy. It is suitable for both city and country roads, that are made of cement, asphalt, or mud. This bicycle is cheaper, simpler in construction & can be widely used for short distance travelling especially by school children, college students, office goers, villagers, postmen etc. It is very much suitable for young, aged, handicap people and caters the need of economically poor class of society. It can be operated throughout the year free of cost.

VII. FUTURE SCOPE

In present project, Hybrid powered electric bicycle uses solar power as one of the energy source. In future wind can also be used as a one of energy source by placing wind turbine at convenient place. Hybrid bicycle can be modified further and make it to use for physically disabled people. Even Bicycle can be digitalized by fitting indicators, advance sensors, digital display, Navigation system etc. Gear variation system can also be implemented to increase torque and control speed

REFERENCES

- [1] The Pandit G. Patil, Energy Systems Division, Argonne National Laboratory “Advanced Battery Technology for Electric Two-Wheelers” Journal of Energy Systems Division, Argonne National Laboratory June 2019.
- [2] Jean-Marc Timmermans¹, Julien Matheys, Philippe Lataire, Joeri Van Mierlo, Jan Cappelle² “A Comparative Study of 12 Electrically Assisted Bicycles” World Electric Vehicle Journal Vol. 3 - ISSN 2032-6653 - © 2019 AVERE.
- [3] Ahmad A. Pesaran and Tony Markel, Harshad S. Tataria, David Howell “Battery Requirements for Plug-In Hybrid Electric Vehicles – Analysis and Rationale” Conference Paper of National Renewable Energy Laboratory, USA NREL/CP-540-42240 July 2019.
- [4] Tony Markel, Michael Kuss, and Paul Denholm “Communication and Control of Electric Drive Vehicles Supporting Renewables” Conference Paper of Center for Transportation Technologies and Systems National Renewable Energy Laboratory, NREL/CP-540-46224 August 2019.
- [5] T. Markel, K. Bennion and W. Kramer, National Renewable Energy Laboratory & J. Bryan and J. Giedd Xcel Energy “Field Testing Plug-in Hybrid Electric Vehicles with Charge Control Technology in the Xcel Energy Territory.” Technical Report of National Renewable Energy Laboratory, NREL/TP-550-46345, August 2009.
- [6] T. Markel, K. Bennion and W. Kramer, National Renewable Energy Laboratory & J. Bryan and J. Giedd Xcel Energy “Field Testing Plug-in Hybrid Electric Vehicles with Charge Control Technology in the Xcel Energy Territory” Journal of International Conference on Renewable Energies and Power Quality (ICREPQ’11) Las Palmas de Gran Canaria (Spain), 13th to 15th April, 2011.
- [7] C. E. (Sandy) Thomas” Fuel Cell and Battery Electric Vehicles Compared” Journal of H2Gen Innovations, Inc., Alexandria, Virginia, 22304, USA.
- [8] Todd Litman, “Efficient Vehicles Versus Efficient Transportation “comparing transportation energy conservation strategies. Journal paper of Victoria Transport Policy Institute 26 August 2009.
- [9] An MIT Energy Initiative Symposium, “Electrification of the Transportation System”. Journal paper of An MIT Energy Initiative Symposium April 8, 2010.
- [10] Chetan Kumar Maini, Deputy Chairman and Chief Technology officer, Reva Electric Car Company, India “Development of a next generation Electric Car for World Markets” Journal of EVS 24 Stavanger, Norway, May 13-16, 2009.