

ANTI SLEEP ALARM FOR DRIVER'S SAFETY

**MOUNIKA VELISHALA, YASHWITHA DONGARI, VENNELA KANAPARTHI,
KULA VARDHAN REDDY SAMA
M. BASHA, Associate Professor,
Department of ECE, Anurag Engineering College, Ananthagiri (V&M),
Suryapet (District), Telangana - 508206
mbasha.ece@anurag.ac.in**

Abstract: - The main purpose behind this project is “Drunk and Drive detection”. Now a days, many accidents are happening because of alcohol consumption of the driver. Thus, drunk driving is a major reason of accidents all over the world. Alcohol Detection in Cars is designed using sensors for the safety of the people seating inside the car. This device should be fitted / installed inside the vehicle and the GPRS is connected to the micro controller where messages are sent to nearby police station if the person is drunk.

Key Words: Breath Analyzer, MQ3 Sensor, Buzzer, Motor, GPRS.

I. INTRODUCTION

The main purpose behind this project is “Drunk driving detection”. In current days several accidents are happening due to the alcohol consumption of the motive force or the one that is driving the vehicle. So drunk driving may be a major reason of accidents in the majority countries everywhere the globe. Alcohol Detector in automotive project is meant for the protection of the folks seating within the automotive. This project ought to be fitted / put in within the vehicle.

Drunk driving is associate degree unfortunate reality that exists in our world these days and causes several problems and tragedies for folks in several places. Drivers have the responsibility to form certain that they're sober and capable of driving to their destination so they don't endanger the lives of others still as themselves.

Drinking will appear harmless, however isn't after you are attending to operate an outsized vehicle that might take the lives of innocent folks once used improperly. for each forty-eight minutes on a median a drunk driver can drive drunk cardinal times before being force over! to boot, drunk driving effects even a lot of folks than it appears as a result of it prices every adult during this country around

Furthermore, as several together in 3 folks are going to be concerned

in associate degree alcohol connected crash in their period. several drunk drivers don't notice their drawback and whose licenses area unit suspended still drive, and thus endanger the lives of themselves and folks around them. lastly, drunk driving could be a major drawback that folks ought to remember of in order that they will notice the problem and hopefully try and stop and avoid it.

To eradicate "Drunk and Drive system" and to reduce the burden of police men we are proposing alcohol detection system in vehicles. "Alcohol Detection sensor" can be used in the various vehicles for detecting whether the driver has consumed alcohol or not, and an alert message is sent to nearby police station if the person is drunk through GSM modem. In the existing system, alcohol detectors are not proposed in any of the vehicles, hence there is a chance for anyone to drink and drive. Traffic police uses alcohol detectors to avoid drunk and drive system. In this project, we are going to introduce alcohol sensors, micro controller, LCD display, Relay for controller and GSM modem to provide an automatic safety system for cars and other vehicles as well. At first, we have formulated the problem by knowing what are the problems we are daily coming across in our day-to-day life.

Next, we have come to know that "Drunk and drive" is one of the major problems we are facing. We have done some research on our project and finally we have come up with this solution. Now our task is to collect the appropriate materials which are used to solve this problem. The materials we need are Alcohol sensor, micro controller, LCD display, Relay for controller and GSM modem. Finally, we design an efficient and enhanced technology. The main unit of this project is an "Alcohol sensor". If the person inside car has consumed alcohol, then it is detected by the sensor. Sensor gives this signal to a comparator IC. The output of comparator is connected to the microcontroller. Microcontroller is the heart of this project. It is the CPU of the complete circuit. Microcontroller gives high pulse to the buzzer circuit and the buzzer is turned on. At the same time, an alert message is sent to nearby police station through GSM modem.



Fig 1 Module sample

II. EXISTING SYSTEM

In the existing system, alcohol detectors are not proposed in any of the vehicles, hence there is a chance for anyone to drink and drive. Traffic police uses alcohol detectors to avoid drunk and drive system.

III. PROPOSED SYSTEM

In this project, we are going to introduce alcohol sensors, micro controller, LCD display, Relay for controller and GSM modem to provide an automatic safety system for cars and other vehicles as well.

IV. HARDWARE DESCRIPTION

Alcohol Sensor

This alcohol sensor is suitable for detecting alcohol concentration on your breath, just like your common breathalyzer. It has a high sensitivity and fast response time. Sensor provides an analog resistive output based on alcohol concentration. The drive circuit is very simple; all it needs is one resistor. A simple interface could be a 0- 3.3V AD.

Sensitive material of MQ-3 gas sensor is SnO₂, which with lower conductivity in clean air. When the target alcohol gas exists, the sensor's conductivity gets higher along with the gas concentration rising. Users can convert the change of conductivity to correspond output signal of gas concentration through a simple circuit. MQ-3 gas sensor has high sensitivity to alcohol gas and can resistant to the interference of gasoline, smoke and vapor. It is with low cost and suitable for various applications of detecting alcohol at different concentration.

Features of Alcohol detector

- ✓ It has sensible sensitivity to alcohol in wide selection, and has benefits like long period of time, low value and easy drive circuit & etc.
- ✓ Touch water Sensitivity of the sensors are going to be reduced once spattered or swaybacked in water.
- ✓ Freezing Do avoid icing on sensor's surface, otherwise sensing material are going to be broken and lost sensitivity.
- ✓ Applied voltage on detector mustn't be over stipulated worth, though the detector isn't physically broken or broken, it causes down-line or heater broken, and produce on sensors' sensitivity characteristic modified badly.
- ✓ Voltage on wrong pins for six pins detector, Pin 2&5 is heating electrodes, Pin (1,3)/(4,6) area unit testing electrodes (Pin one connects with Pin three, whereas Pin four connects with Pin 6).If apply voltage on Pin 1&3 or 4&6, it'll build lead broken; and no signal out if apply on pins 2&4

Digital Display

Liquid Crystal show that is often referred to as {LCD liquid crystal show, LCD, digital display, alphanumeric display} is a display it means it will display Alphabets, Numbers similarly as special symbols therefore {lcd | liquid crystal show | LCD | digital show | alphanumeric display} may be a user-friendly show device which might be used for displaying varied messages not like seven section display which might display solely numbers and a few of the alphabets. Here we've used sixteen x a pair of {alphanumeric show | digital show | display} which suggests on this display we are able to display 2 lines with most of sixteen characters in one line.

DC Motor

A DC motor may be a automatically commutated motor steam-powered from DC (DC). In DC motor, operation is predicated on easy electromagnetism. A current-carrying conductor generates a field; once this can be then placed in associate degree external magnetic field, it'll expertise a force proportional to the present within the conductor, and to the strength of the external field. Opposite (North and South) polarities of magnet attract, whereas like polarities (North and North, South and South) repel, the inner configuration of a DC motor is intended to harness the magnetic interaction between a current-carrying conductor associate degree an external field to come up with motility motion.

Micro controller (AT89S52)

Microcontroller could be a general-purpose device, that integrates variety of the parts of a microchip system on to single chip. it's constitutional central processing unit, memory and peripherals to create it as a mini pc. A microcontroller combines on to an equivalent microchip: • The central processing unit core

- Memory(both memory board and RAM)
- Some parallel digital i/o Microcontrollers can mix different devices such as:

- A timer module to permit the microcontroller to perform tasks certainly time periods.

- A serial I/O port to permit knowledge to flow between the controller and different devices like a PIC or another microcontroller.

- An ADC to permit the microcontroller to simply accept analogue computer file for process. Microcontrollers are:

- Smaller in size
- Consumes less power
- cheap small controller could be a standalone unit, which might perform functions on its own with none demand for added hardware like I/O ports and external memory. The heart of the microcontroller is that the central processing unit core. within the past, this has historically been supported an 8-bit microchip unit. as an example, Motorola uses a basic 6800. microchip core in their 6805/6808 microcontroller devices. AT89S52 is that the forty pins, eight-bit Microcontroller factory-made by Atmel cluster. it's the flash kind reprogrammable memory. Advantage of this nonvolatile storage is we are able to erase the program inside couple of minutes. it's 4kb on chip memory board and 128 bytes internal RAM and thirty-two I/O pin as organized as port zero to port three every has eight-bit bin.

Port zero contain eight knowledge line(D0-D7) furthermore as low order address line (A0-A7). Port a pair of contain higher order address line (A8-A15). Port three contains special purpose register like serial input receiver register SBUF, interrupt INTO,INT1 and timers T0 , T1 several of the pins have multi performs which might be used as general purpose I/O pins (or) Special purpose function may be determined by the applied scientist itself

Characteristics of AT89S52

- 8K Bytes of In-System Reprogrammable nonvolatile storage
- absolutely Static Operation: zero cps to twenty four megacycle
- Three-Level Program Memory Lock

- 256 x 8-Bit Internal RAM
- thirty two Programmable I/O Lines
- 2 16-Bit Timer/Counters
- Six Interrupt Sources
- Programmable Serial Channel
- Low Power Idle and Power Down Modes

Power Supply

The ac voltage, typically 220V rms, is connected to a transformer, which steps that ac voltage down to the level of the desired dc output. A diode rectifier then provides a full-wave rectified voltage that is initially filtered by a simple capacitor filter to produce a dc voltage. This resulting dc voltage usually has some ripple or ac voltage variation. A regulator circuit removes the ripples and also remains the same dc value even if the input dc voltage varies, or the load connected to the output dc voltage changes. This voltage regulation is usually obtained using one of the popular voltage regulator IC units.

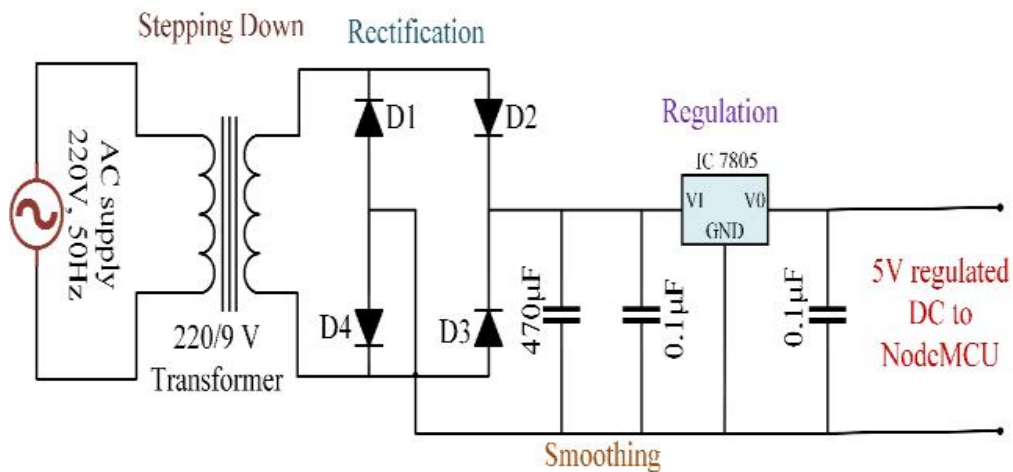

Fig 2 Power supply module

Working principle

Transformer The potential electrical device can step down the facility offer voltage (0-230V) to (0-6V) level. Then the secondary of the potential electrical device are connected to the exactness rectifier, that is built with the assistance of op- amp. the benefits of victimization exactness rectifier area unit it'll provide peak voltage output as DC, remainder of the circuits can provide solely RMS output.

Keil Introduction

Keil small Vision is free software package that solves several of the pain points for associate degree embedded program developer. This

software package is associate degree integrated development surroundings (IDE), that integrated a text editor to put in writing programs, a compiler and it'll convert your ASCII text file to hex files too. Here is straightforward guide to begin operating with Keil u Vision which might be used for

- Writing programs in C/C++ or programming language
- Compiling and aggregation Programs
- Debugging program
- Creating Hex file
- Testing your program while not offered real Hardware (Simulator Mode) These area unit the straightforward steps to urge off the mark your inning!

Step 1: once gap Keil uV4, head to Project tab and build new uVision project Now choose new folder and provides name to Project.

Step 2: once making project currently choose your device model. AT89S52 [You will modification it later from project window.]

Step 3: Therefore currently your project is made and Message window can seem to feature startup file of your Device click on affirmative therefore it'll be side to your project folder

Step 4: currently head to File and build new file and put it aside with .C extension if you'll write program in C language or save with .asm for programming language.

Step 5: currently write your program and put it aside once more.

Step 6: subsequently on left you see project window [if it's not there go to read tab and click on project window] currently come back on Project window. Click output tab here & check produce Hex file if you wish to get hex file currently ok therefore it'll save changes.

Step 7: currently Expand target and you'll see supply cluster Right click on cluster and click on on Add files to supply cluster. Now add your program file that you have got written in C/assembly. You can see program file side below supply cluster.

Step 8: currently Click on Build target. you'll be able to realize it below Project tab or in toolbar. It can also be done by pressing F7 key.

Step 9: you'll be able to see standing of your program in Build output window [If it's not their head to read and click on on Build output wind

IV. PROJECT DESCRIPTION

Drunk driving may be a major reason of accidents in the majority countries everywhere the planet. Alcohol Detector in automotive project is meant for the security of the folks seating within the automotive. This project ought to be fitted / put in within the vehicle.

Working:

The alcohol device that is connected to port one,3rd pin has wood spirit share.

Whenever the alcohol share of the motive force exceeds the limit of alcohol device, then the ignition (motor) that is connected to port one.0 stops mechanically. A message showing “Detected” is displayed on the digital display that is connected to port zero. At constant time buzzer that is connected to port one, 5th pin is ON acting as a warning to the motive force.

If the alcohol share of the motive force doesn't exceed the device alcohol content, then a message “no alcohol motor on” is displayed on the digital display screen.

Advantages

- This circuit detects the alcohol directly.
- This circuit is simple in construction.
- Readily available ICs are used.
- Responsibility of the circuit is high.
- High Accuracy.



Fig 3 Hardware Kit Result 1

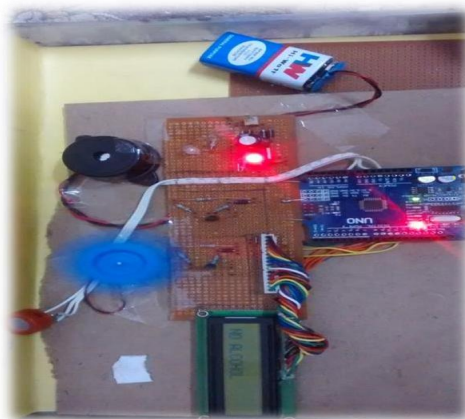

Fig 4 Hardware Kit Result 2

V. CONCLUSION

As majority of accidents occurring nowadays are thanks to drunk driving, thus a good methodology to forestall this is often to develop an associated Integrated Drunk and Drive Detection. Integrated Drunk associated Drive Detection system is meant with an economical and increased technology. The main unit of this project is associated "Alcohol sensor". If the person within automobile has consumed alcohol, then it's detected by the sensing element. Sensing element provides this signal to a comparator IC. The output of comparator is connected to the microcontroller. Integrating options of all the hardware parts used are developed in it. Presence of each module has been reasoned out and placed fastidiously, therefore conducive to the simplest operating of the unit.

Future Scope

Integrated Drunk and Drive Detection system detects solely the driver's state. This could even be extended by incorporating an extra alcohol sensor at the traveller seats to discover the presence of alcohol within the air within the vehicle cabin. Once alcohol is detected, the system provides each a voice alert and a message alert on the navigation system monitor.

VI. REFERENCES

1. <http://www.indiaenvironmentportal.org.in/files/file/road%20accidents%20in%20India%202017.pdf>
2. <https://scroll.in/article/908022/more-than-2000-people-were-booked-for-drink-driving-in-indias-big-cities-on-new-years-eve>
3. <https://indiacode.nic.in/bitstream/123456789/1798/3/A1988-59.pdf>
4. Vijay Savania, Hardik Agravata and Dhruvil Patela, Alcohol Detection and Accident Prevention of Vehicle, International Journal of Innovative and Emerging Research in Engineering, Volume 2, Issue 3, 2015
5. M. Malathi, R. Sujitha and M. R. Revathy, Alcohol detection and seat belt control system using Arduino, 2017 International Conference on Innovations in Information, Embedded and Communication Systems (ICIIECS), pp. 1-3, Coimbatore, 2017.
6. Dada Emmanuel Gbenga, Hamit Isseini Hamed, et al. Alcohol Detection of Drunk Drivers with Automatic Car Engine Locking System, Nova Explore Publications, Nova Journal of Engineering and Applied Sciences, Vol.6 (1) 2017
7. Aryan Mathur, Driver Alcohol Detection System, International Journal of Scientific & Engineering Research, Volume 4, Issue 5, May-2013
8. Prof. Dr. D.G. Jha, Swapnil Buva Alcohol Detection in Real-Time To Prevent Drunk Driving IOSR Journal of Computer Engineering

(IOSR-JCE) ,PP 66-71

9. <https://store.arduino.cc/usa/arduino-uno-rev3>
10. <https://components101.com/switches/mq-3-sensor>
11. <https://components101.com/switches/push-button>
12. <https://components101.com/motors/toy-dc-motor>
13. <https://www.electronicshub.org/gsm-gprs-module/>
14. <https://components101.com/diodes/5mm-round-led>